



JIS-10K 球狀石墨鑄鐵伸縮囊密封型球型閥

JIS-10K Ductile Iron Bellows Sealed Globe Valve

FIG FJ38D



Selection of possible applications:

- Industry
 - Powerstations
 - Flue gas purification plant
 - Processing technology
 - Gas supply
 - Vapour facilities
 - Thermal oil applications
 - Recycling facilities
 - Vacuum facilities
 - Ammonia
 - Hot water
 - Heating technology
 - District heating
 - Cooling and freezing systems
 - General plant manufacturing
 - Steam systems
- other applications on request -

Design Description:

- Globe valve in straight way type
- Bolted bonnet
- Outside screw and yoke
- Antirotation device and mechanical position indicator
- Rising stem and non-rising handwheel
- Disc with conical metallic sealing surface
- Metal back seat, safety stuffing box packing
- Lubricating Nipple as Standard
- Secondary Sealing : gland packing
- Design and manufacture acc. to JV4-4 JV4-5
- Stem sealed with bellows tested for 5,000 full open/closed operations at 20°C
- Shell wall thickness acc. JIS 2031
- Face to face dimensions acc. to JIS B2002
- Flanges acc. to JIS B 2210 10K
- The Valve are marked to JIS B 2004
- Test pressure Dimensional Inspection acc. to JIS B2003
- Maintenance free
- Free From asbestos, PCB and CFC

Pressure/Temperature Ratings:

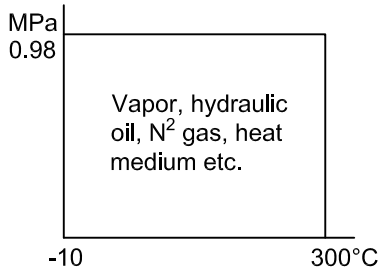

Inspection pressure	
Body	Water pressure 1.47 MPa
Body seat	Water pressure 1.08 MPa



JIS-10K 球狀石墨鑄鐵伸縮囊密封型球型閥

JIS-10K Ductile Iron Bellows Sealed Globe Valve

FIG FJ38D

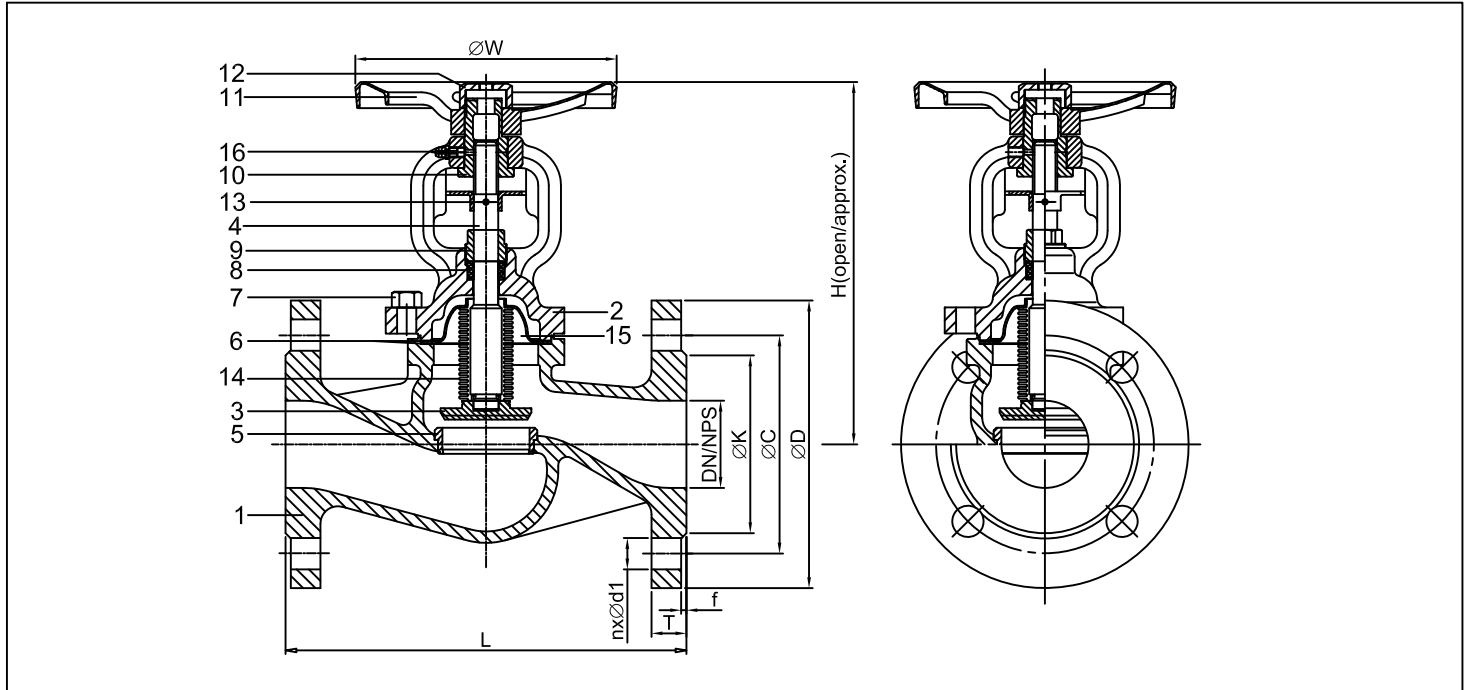

Valve Parts List:

Item	Part name	Material	Remarks
1	Body	FCD 450-10	FCD-S on request
2	Bonnet	FCD 450-10	
3	Disc*	SUS 410	HF on request
4	Stem	SUS 410	
5	Body Seat	SUS 410	HF on request
6	Gasket	Graphite	
7	Bonnet Bolts	SS 400	
8	Gland Packing	Graphite	
9	Gland	C3604	
10	Stem nut	C3604	
11	Handwheel	FCD 450-10	
12	Handwheel nut	FCD 450-10	
13	Position indicator	SS 400	
14	Bellows	SUS 304	
15	Bellows Flange	SUS 304	
16	Lubricating Nipple	SUS 304	

* Soft disc inserts available for gas or vacuum service

Dimensions Table:

Unit : mm

SIZE		H	ØW	L	JIS 10K						a
DN	NPS				ØD	ØC	ØK	nxØd1	T	f	
15	1/2"	159	125	108	95	70	51	4x15	12	1	3.5
20	3/4"	159	125	117	100	75	56	4x15	14	1	3.5
25	1"	159	125	127	125	90	67	4x19	14	1	4
32	1-1/4"	216	150	140	135	100	76	4x19	16	2	4.5
40	1-1/2"	211	150	165	140	105	81	4x19	16	2	5
50	2"	211	150	203	155	120	96	4x19	16	2	5.5
65	2-1/2"	266	175	216	175	140	116	4x19	18	2	6.5
80	3"	266	175	241	185	150	126	8x19	18	2	7
100	4"	350	300	292	210	175	151	8x19	18	2	8
125	5"	358	300	356	250	210	182	8x23	20	2	9
150	6"	395	300	406	280	240	212	8x23	22	2	9
200	8"	530	400	495	330	290	262	12x23	22	2	10