



Class 150 鑄鋼/鑄不銹鋼伸縮囊密封型閘門閥
 Class 150 Cast Steel/Cast Stainless Steel
 Bellows Sealed Gate valve

FIG FN49 Series



Selection of possible applications:

- Industry
 - Powerstations
 - Flue gas purification plant
 - Processing technology
 - Gas supply
 - Vapour facilities
 - Thermal oil applications
 - Recycling facilities
 - Vacuum facilities
 - Ammonia
 - Hot water
 - Heating technology
 - District heating
 - Cooling and freezing systems
 - General plant manufacturing
 - Steam systems
- other applications on request -

Design Description:

- Bolted bonnet
- Outside screw and yoke
- Flexible wedge, Fully Guided
- Renewable seat ring
- Rising stem and non-rising handwheel
- Metal back seat
- Lubricating Nipple as Standard
- Secondary Sealing : gland packing
- Renewable bellows sealed bonnet assembly
- Different types of connection available.
(Butt Weld, and Flange Ends)
- Stem sealed with bellows tested for 3,000 full open/closed operations at 20°C
- Design and Manufacturing acc. to API 600
- Shell wall thickness acc. ASME B16.34
- Butt Weld Ends acc. to ASME B16.25
- Flanges Ends acc. to ASME B16.5
- Flanges face to face dimensions acc. to ASME B16.10
- Test pressure acc. to API 598
- Maintenance free
- Free from abestos,PCB and CFC

Pressure/Temperature Ratings:

	BODY Material	Temp.	Working Pressure	SHELL TEST (water)	SEAT TEST (water)	SEAT TEST (air)
Class 150	A351 Gr.CF8/ Gr.CF8M	100°F 38°C	275 psig 19 bar	425 psig 29 bar	305 psig 21 bar	80 psig 5.5 bar
		1000°F 538°C	20 psig 1.4 bar			
	A 216 Gr.WCB	100°F 38°C	285 psig 19.6 bar	450 psig 31 bar	315 psig 22 bar	80 psig 5.5 bar
		800°F 425°C	80 psig 5.5 bar			

Valve Parts List:

Item	Part name	Material		
		A216-WCB	A351-CF8	A351-CF8M
1	Body	A216-WCB	A351-CF8	A351-CF8M
2	Seat ring	410SS	304SS	316SS
3	Wedge	A216-WCB	A351-CF8	A351-CF8M
4	Stem	13%Cr	S.S.304	S.S.316
5	Gasket	Grafoil+304Sheet	Grafoil+304Sheet	Grafoil+316Sheet
6	Bonnet	A216-WCB	A351-CF8	A351-CF8M
7	Bellows	S.S.304	S.S.304	S.S.316
8	Packing	Graphite	Graphite	Graphite
9	Gland	13%Cr	A351Gr.CF8	A351Gr.CF8
10	Gland Flange	A216-WCB	A351-CF8	A351-CF8
11	Eye Bolts	A307-B	A193-B8	A193-B8M
12	Eye Bolt Nut	A194-2H	A193-B8	A194-8M
13	Eye Bolt Pin	A36	A276-304	A276-304
14	Bonnet bolt	A193-B7	A193-B8	A194-8M
15	Bonnet nut	A194-2H	A194-8	A194-8M
16	Stem nut	A439-D2	A439-D2	A439-D2
17	Handwheel	Ductile Iron	Ductile Iron	Ductile Iron
18	Handwheel nut	Ductile Iron	Ductile Iron	Ductile Iron
19	Upper Bellows Joint	13%Cr	S.S.304	S.S.316
20	Lower Bellows Joint	13%Cr	S.S.304	S.S.316
21	Lubricating Nipple	S.S.304	S.S.304	S.S.304

**Seating face with stellite is on request.



Class 150 鑄鋼/鑄不銹鋼伸縮囊密封型閘門閥
 Class 150 Cast Steel/Cast Stainless Steel
 Bellows Sealed Gate valve

FIG FN49 Series

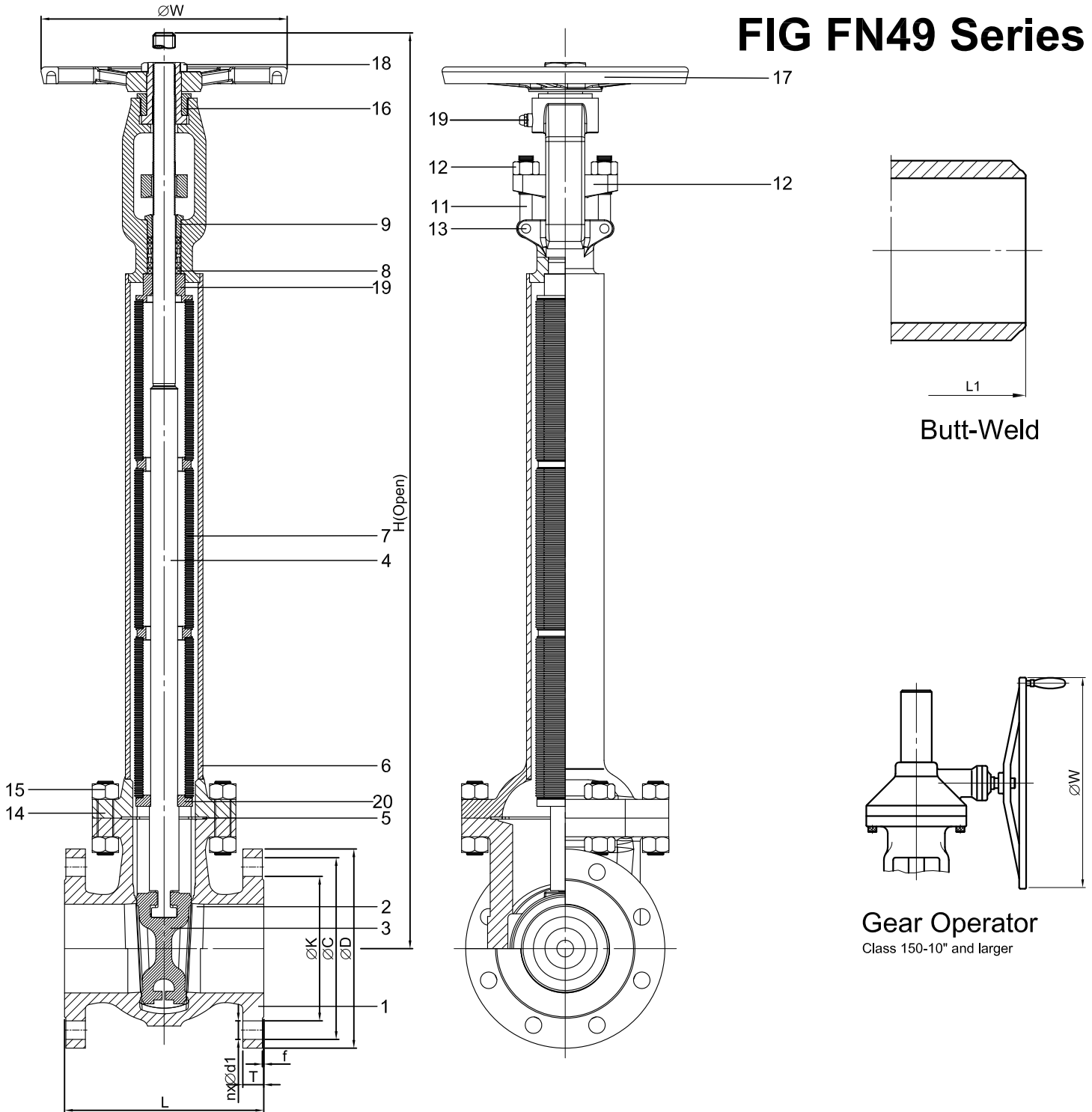

Dimensions Table:

Unit : mm

SIZE		L	L1	ØW	H	h	CLASS 150					
DN	NPS						ØD	ØC	ØK	nxØd1	T	f
50	2"	178	216	180	671	610	152	120.5	92	4xØ19	15.9	1.6
65	2-1/2"	191	241	180	870	777	178	139.5	105	4xØ19	17.5	1.6
80	3"	203	282	250	870	777	190	152.5	127	4xØ19	19.1	1.6
100	4"	229	305	250	1511	1350	229	190.5	157	8xØ19	23.9	1.6
150	6"	267	403	400	1595	1421	279	241.5	216	8xØ22	25.4	1.6
200	8"	292	419	400	1671	1435	343	298.5	270	8xØ22	28.6	1.6
250	10"	330	457	600	2080	1800	406	362	324	12xØ25	30.2	1.6
300	12"	356	502	600	2410	2100	483	432	381	12xØ25	31.8	1.6
350	14"	381	572	600	2700	2350	533	476.5	413	12xØ29	35	1.6
400	16"	406	610	600	3030	2620	597	539.5	470	16xØ29	36.6	1.6

Larger sizes available on request